

# Axoplus 95 series

Versatility in recipes

Up to 48 kg of dough\*

High shearing power for stiff doughs and high stretching capacity for more hydrated doughs.

The three-arm tool version is particularly suited for producing pizza dough and food products.



- Electrical lifting of the mixing arm
- Powered bowl
- Precision thanks to tool and bowl speed variation
- Mounted on wheels for easy movement



For more information:



Video



Commercial documentation

\* Maximum dough capacity. Example for an average hydration rate of 60%. More information here.



Contents

# Fork mixer with fixed bowl Axoplus 95

## General Features



- Motorized stainless steel bowl
- User-friendly control panel
- Heightened frame on wheels
- Electric head lifting
- 2 motors: bowl and tool
- Clear bowl cover with access door
- 200/240 V single phase + Earth - 50/60 Hz (any other specific voltage available and free of charge providing that it is technically possible)
- Power: 1,75 kW
- Intensity: 16 A
- IP 54



Axoplus 95 Evolution  
3-branch aluminium arm

## AXOPLUS 95 EVOLUTION



Code: B503057

- Automatic/programmable cycle
- Recipe programming
- Variable bowl and tool speeds
- 2-branch aluminium arm for all types of dough

## AXOPLUS 95 EVOLUTION

Code: B503057-3A

- Automatic/programmable cycle
- Recipe programming
- Variable bowl and tool speeds
- 3-branch aluminium arm recommended for the production of pizza dough

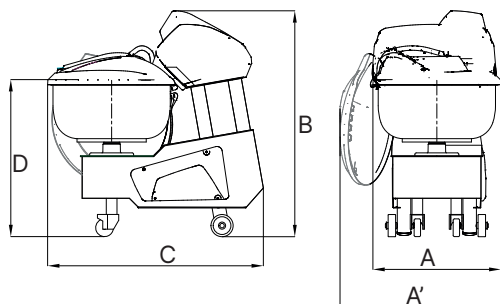

Capacity motorized bowl	AXOPLUS 95
Total bowl volume (l)	95
Max. dough capacity (kg)*	48
<b>Weight (kg)</b>	205
Dimensions (mm)	
Width (A)	750
Total width (A')	910
Height closed (B)	1320
Depth (C)	1230
Bowl height(D)	875
Bowl diameter Ø	657

\*Example for an average hydration rate of 60%.  
More information here.

See conditions on page 5

Important : accessory orders that are disconnected from a machine order will be processed by our after-sales department.